

# New investigations of the mechanisms of lightning strike to radomes

## Part I : Experimental study in high voltage laboratory

**A. Ulmann, P. Brechet**  
DGA/DCE/CEAT

**A. Bondiou-Clergerie, A. Delannoy, P. Lalande, P. Blanchet, P. Laroche**  
ONERA

**E. Bocherens**  
DGA/SMA/AIA-CP

**G.L. Bacchiega, I. Gallimberti**  
IRS

Copyright © 2001 Society of Automotive Engineers, Inc.

### ABSTRACT

The main purpose of the experiments described here is the analysis of the mechanisms of radome protection with lightning diverters of various types and sizes. A high voltage arrangement and associated diagnostics have been implemented to perform a quantitative study of the inception and propagation mechanisms of the corona and leader discharges that precede the final breakdown. It is shown that ambient humidity plays a significant role on the discharge process and that the nature of the discharge initiated from the strip is very different depending on the strip type. Segmented strips are more likely to allow energetic discharges to propagate from an internal antenna leading to radome puncture.

### INTRODUCTION

The protection from lightning strikes of aircraft radomes located in zone 1A is usually accomplished through a combination of several diverters of adequate type and length. Segmented strips and solid strips are two customary types and both aims to force the lightning arc path. RF transmission efficiency is strongly influenced by protection schemes and it is therefore necessary to optimize their characteristics. A former study called the Joint Radome Programme [1] was set up between March 93 and April 97 to investigate the effects of lightning and static electricity on aircraft radomes. Interesting conclusions raised from the program leading to a

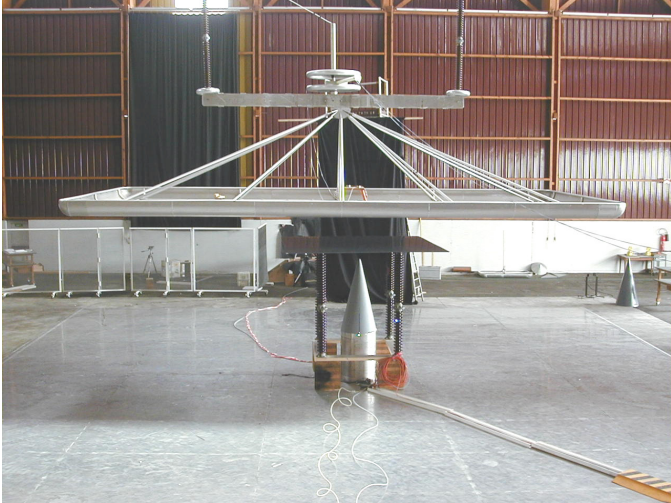
redefinition of ground based high voltage test procedure after complementary analysis from the Round Robin Radome program piloted by AE2 and EUROCAE comities. In 1997, a French consortium was constituted with a radome manufacturer (AIA/CP), research centers (ONERA, IRS) and a test center (CEAT) to improve the knowledge of lightning interaction with radomes and their associated protection systems. The final delivery is a numeric model able to predict the optimized protection scheme in some conditions. The objective of this paper is to describe the experimental observations obtained in the test campaigns. A companion paper [2] explains how the observations can be interpreted to set up the basis of a core model.

After a presentation of the experimental set up the results obtained in respectively dry and wet ambient humidity will be discussed.

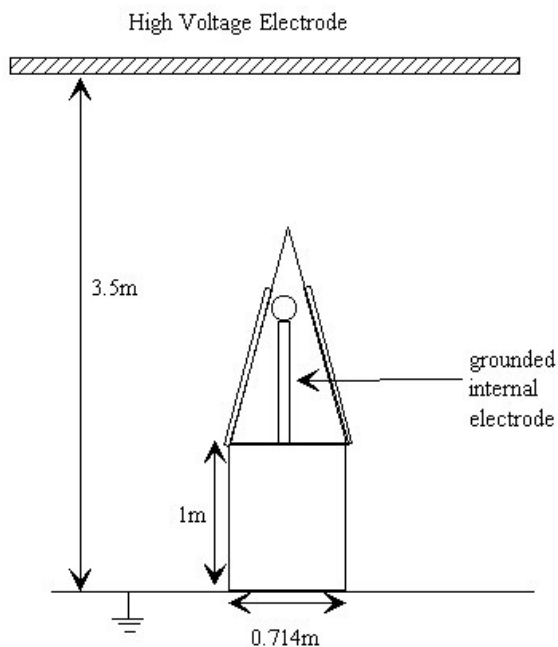
### EXPERIMENTAL CONFIGURATION

The radome has a conic shape and is made of fiber glass and epoxy resin. It is coated with a standard paint and mounted on a conductive cylinder base simulating the fuselage in which instrumentation is located. A grounded rod is located inside the radome and aims to represent radar antenna (**Figure 3**). The protection system is composed of 4 lightning diverters equally distributed around the circumference. Lightning diverters are either solid or segmented strips.

The radome attached to its cylinder is installed inside a plane-to-plane gap which enables to simulate quasi-uniform electric fields (**Figure 1 and Figure 2**). The upper plane is submitted to a negative waveform D voltage. A large PVC interface is located between the radome tip and the upper electrode in order to stop leaders in their propagation and avoid lightning arcs that saturate pictures taken with high speed cameras.

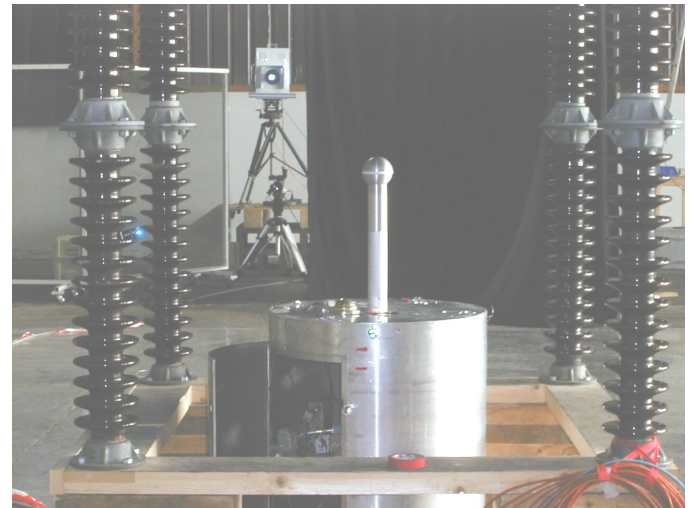


**Figure 1 : Test set up**



**Figure 2 : Size of the experimental set-up**

Electric field measurements are performed under the radome at its base, at the tip of the internal electrode and on the upper plane. These measurements are synchronized with streak camera and current measurements at the rod and at the strips. Output voltage is controlled via a voltage divider.



**Figure 3 : Internal electrode**

## LOW AMBIANT HUMIDITY CONDITION

A first series of experiments is performed in low ambient humidity (<30%) conditions. After a calibration of the internal field at low voltage, the behavior of the 2 types of lightning strips is analyzed. The discharge processes depend on the type of the strips and on, their height.

## CALIBRATION

An analyzing of electromagnetic field conditions inside the radome is performed at first to evaluate the shielding of the radome itself and of the strips. The plane electrode is polarized with a voltage low enough to prevent electric discharges to propagate.

The radome itself, as a perfect dielectric, does not produce any shielding effects. It appears that the shielding produced by solid strip is significant and 4 strips of 40 cm lead to a 6 dB attenuation. Segmented strips have a specific behavior. It has been shown that the shielding effect depends on the frequency : no electric field shielding during the rise time and a shielding effect more and more important during the decay (**Appendix 1, Figure 14 to 16**). This effect is due to their technology, metallic bottoms on a resistive backing, which makes the strips conductive at low frequencies and insulating at higher frequencies.

## SOLID STRIPS STUDY

Strips of 20, 40 and 60 cm height have been implemented on the radome and the discharge processes have been analyzed.

### L > 20cm

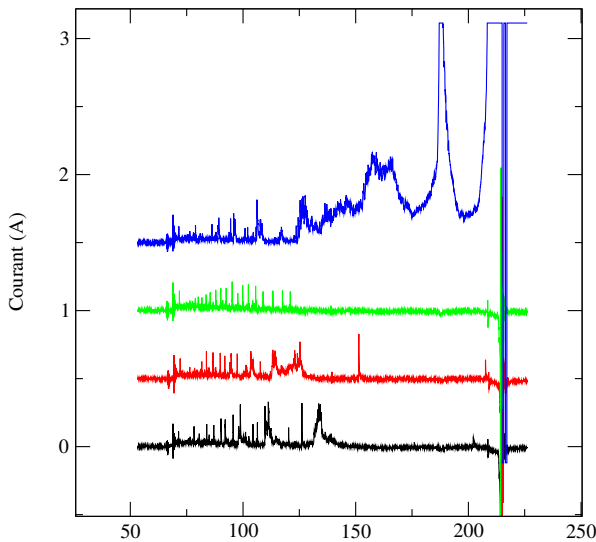
When the strip height exceeds 20cm, a stable leader discharge always initiates from one of the strips ; the electric field at the electrode is too low to enable corona

inception. The development of a leader from one of the strips is visible on **Figure 4**.



**Figure 4 : Leader development from a strip**

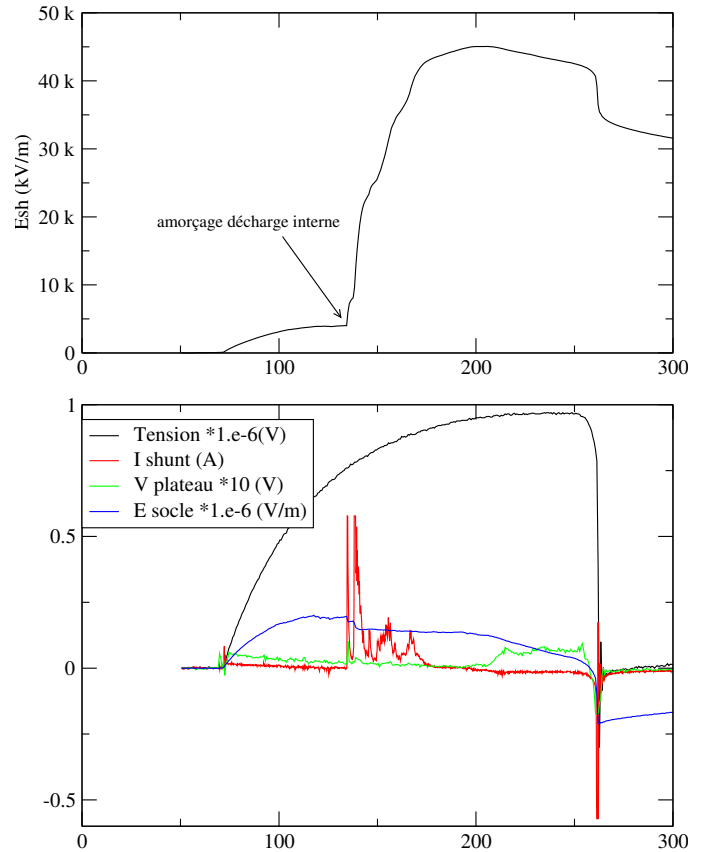
A leader propagating from a strip leads to a quenching of discharge process at the other strips (**Figure 5**). The reason is that a leader developing from a particular strip influences electric field distribution like a conductor of equal length and shields the field at the tip of the other strips.



**Figure 5 : Current measurements at the strips**

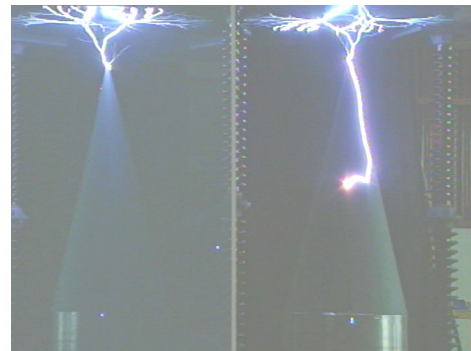
$L \leq 20\text{cm}$

When the strip height is reduced to 20cm, a discharge from the internal electrode is observed in 50% of the cases. (In the other cases, the discharge develops according to a scenario equivalent to the one described in the former chapter). The following example (**Figure 6**) corresponds to a discharge propagating from the internal electrode. In most cases, no punctures of the radome were observed despite an internal discharge of relatively high amplitude (5 to 8  $\mu\text{C}$  deposited on the inner surface of the radome).



**Figure 6 : Current and electric field measurement associated with an internal discharge**

In one case, a puncture has occurred. The still picture shows that a part of the lightning channel was guided along the radome surface (**Figure 7**). The leader that initiated the arc cannot be a positive ascendant type because positive charge deposited by the internal discharge on the inner surface of the radome would have repelled it.



**Figure 7 : Leader development along the surface**

This process can be explained by the inception of a bipolar discharge [2].

## SEGMENTED STRIPS STUDY

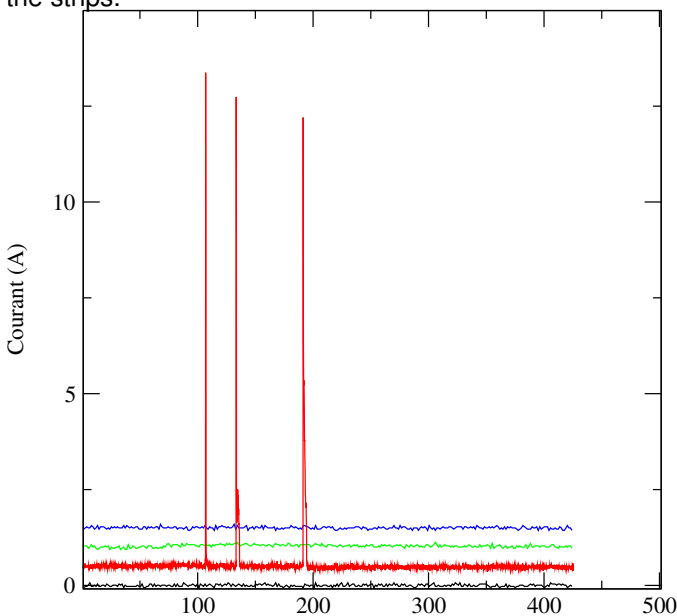
Strips of 40, 80 and 107 cm length have been implemented on the radome and the discharge process has been analyzed.

### H=107cm

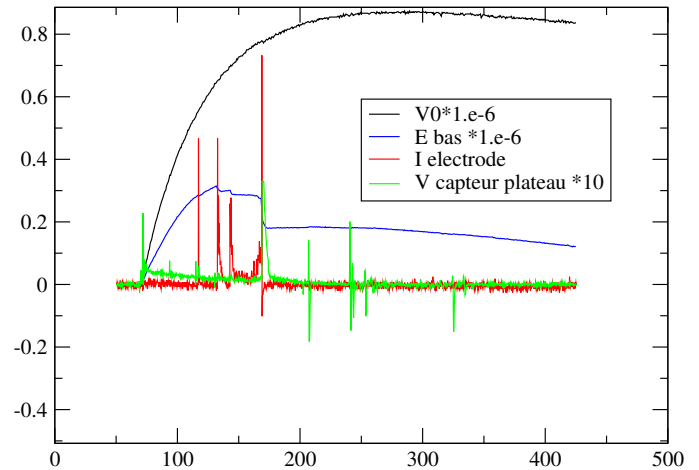
When the strips are 107 cm in length, 2 types of behavior are observed.

- (1) In 50% of the cases, no internal discharge can be detected and very large coronas propagate from the strips (Figure 8). These coronas are repeated 2-3 times during the voltage rise front. They are associated with peak currents higher than 10 A.
- (2) In the other 50% cases, an internal discharge, carrying 5 to 8  $\mu\text{C}$ , is observed to initiate (Figure 9). Measurements indicate that corona discharge start from the strips immediately after the internal leader inception. This can be explained by the electric field enhancement around the strips due to the space charge deposited on the radome internal surface.

In both situations, final breakdown has been initiated on the strips.



**Figure 8 : Current in the segmented strips**



**Figure 9 : Internal discharge**

### H=80cm

A leader discharge always propagates from the internal antenna. If the voltage is high enough, internal discharge can cause the inception of a discharge from one of the strips.

### H=40 cm

In 100% of the cases an internal discharge occurs first. Sometimes the internal discharge forces one of the strips to light up and to emit a corona. In this situation, the protection system effectiveness is strengthened by an internal discharge which is quite a paradoxical situation. Sometimes, puncture of the radome happens. The analysis of this situation indicates that a bipolar discharge is initiated at the radome tip and generates external charges of negative polarity. When the electric field exceeds dielectric strength of the radome, a puncture occurs [2].

## HIGH AMBIANT HUMIDITY CONDITION

A second series of experiments is performed in high ambient humidity (>60%). After a calibration of the internal field at low voltage, the behavior of solid strips is analyzed. The discharge process depends upon the type of the strips and upon their length.

## CALIBRATION

Electric field under the radome is measured at the radome base and at the tip of the internal electrode. If the radome was a perfect dielectric, its presence wouldn't modify internal field. In high ambient humidity conditions, it appears that the electric field at the tip of the electrode is lowered and that the field at the radome base is amplified. It has been shown that this behavior can be explained by a surface conductivity due to humidity absorption. The radome behaves like an isolator in RF domain and becomes conductive at lower frequencies. Thus, when the radome is polarized in a homogeneous

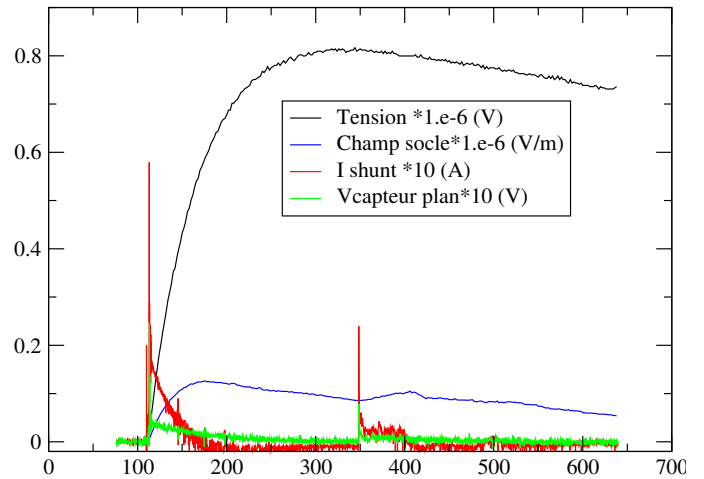
vertical ascendant electric field, negative charges at its base induce a rise of the field in their vicinity. (**Appendix 2, Figure 17**). Measurements at the internal electrode obtained in the same voltage conditions on the radome equipped with solid strips show that non linear shielding due to the surface conductivity of the radome is superposed to the linear shielding of the strips. Measurements at the radome base show that amplification effect due to radome polarization is largely balanced by shielding effects of the strips (**Appendix 2, Figure 18**)

### SOLID STRIPS STUDY

It has been observed that the behavior of the protection system is independent on the strip height. Even for small length (20 cm), there is no discharge from the internal electrode. The final arc glides on the radome surface : this indicates that the driving process is not an ascending positive leader (**Figure 10, Figure 11**)



**Figure 10 : Leader development along the surface**

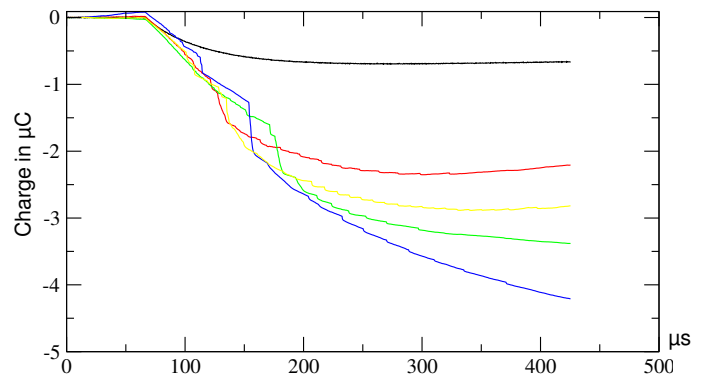


**Figure 11 : Current, High voltage, Electric field variation during the leader development along the surface**

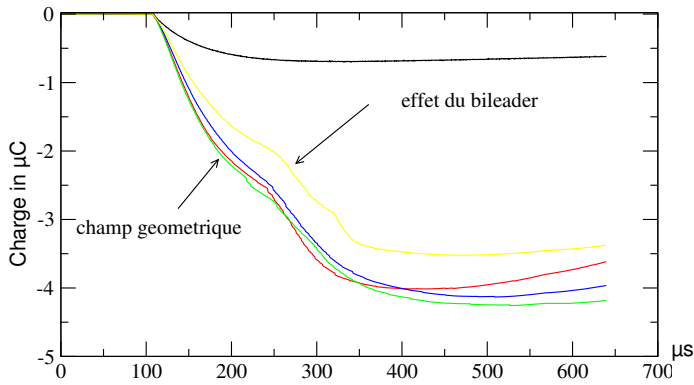
### DISCUSSION

Due to the non linear conductivity of the radome, the behavior of protection strips is very different in high ambient humidity conditions. A comparison of the current in the strips is performed for the radome equipped with 40 cm strips. **Figure 12** and **Figure 13** represent the integration of the current in each strip for respectively high and low ambient humidity conditions. In low ambient humidity conditions, the discharge begins by a sequence of coronas. In high ambient humidity conditions, displacement currents are much stronger than corona currents. The reason is that the radome conductivity strongly reduces the electric field around the strips and then the ionization activity at these points.

It has to be noted that despite the reduction of strip efficiency in high humidity conditions, no puncture of the radome has occurred. The internal field remains too low to enable the inception of a discharge from the internal electrode.



**Figure 12 : Charge at the strips in low ambient humidity conditions**



**Figure 13 : Charge at the strips in high ambient humidity conditions**

## CONCLUSION

Mechanisms involved in the lightning protection of radomes with solid and segmented strips have been analyzed in low ambient humidity conditions. It is shown that from conductive strips stable leaders are initiated that guide the final arc path, provided the strips are of sufficient height. On the other hand, the behavior of segmented strips is unfavorable to the inception of stable leaders and energetic discharges can start from the internal electrode leading to radome puncture. Physical mechanisms involved in radome puncture have been highlighted. It has been shown that a low quality shielding permit the inception of a corona discharge from the internal electrode. Electric field intensification can generate a bipolar discharge that can in some case induce an enhancement of the field inside the material that can generate a breakdown. In high ambient humidity conditions (>60%) the radome becomes moderately conductive because of humidity absorption at its surface. In such conditions, the discharge regime is driven by the inception of a bipolar discharge at the tip of the radome and the discharge activity at the strips is reduced

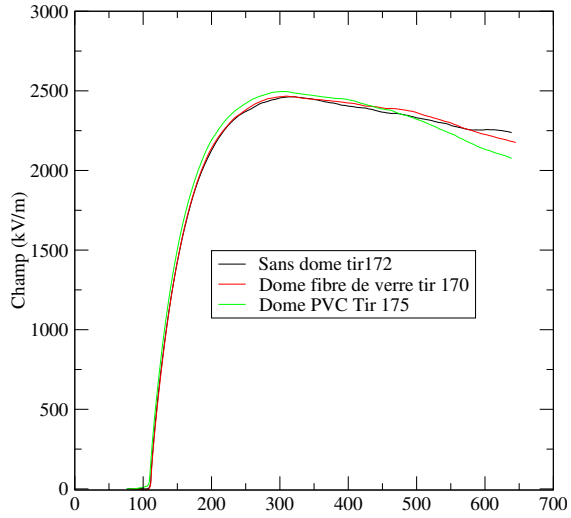
## ACKNOWLEDGMENTS

Work on this project was funded by French MoD/DGA .

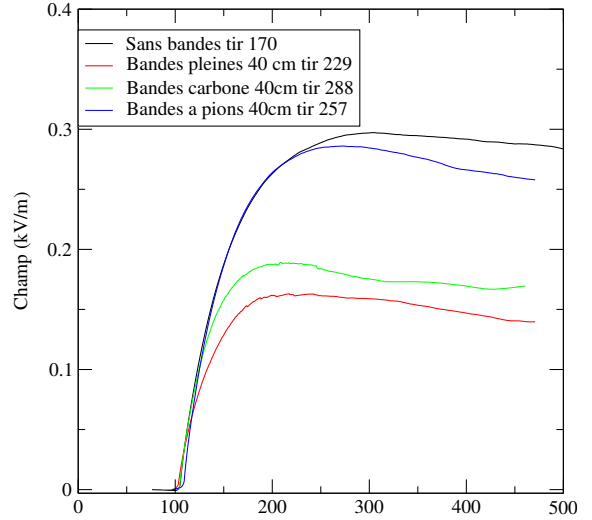
## REFERENCES

1. "Review of the Joint Radome Programme", Hardwick, Plumer, Ulmann, ICOLSE 1999-01-2322
2. "New investigations of the mechanisms of lightning strike to radomes, Part II : Modeling of the protection efficiency", Delannoy and al, ICOLSE 2001-

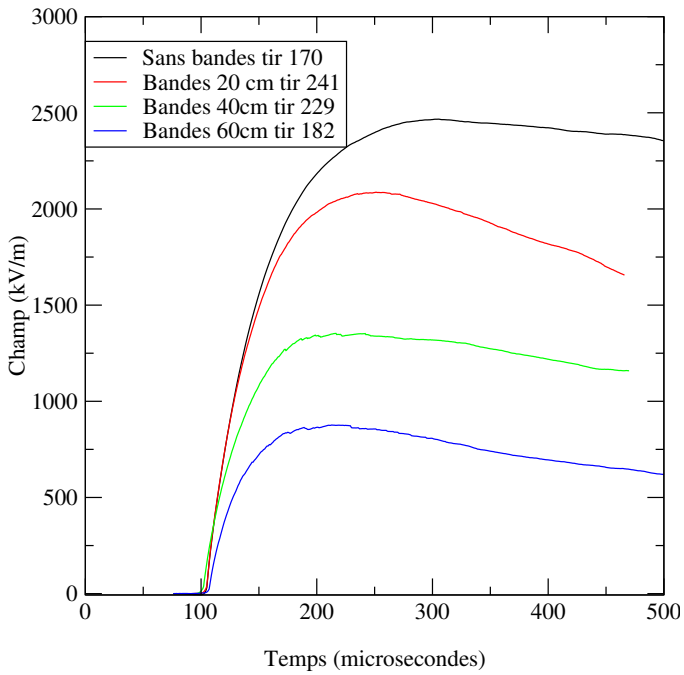
## APPENDIX 1 : DRY AIR CALIBRATION



**Figure 14 : Electric field at internal electrode without strips**

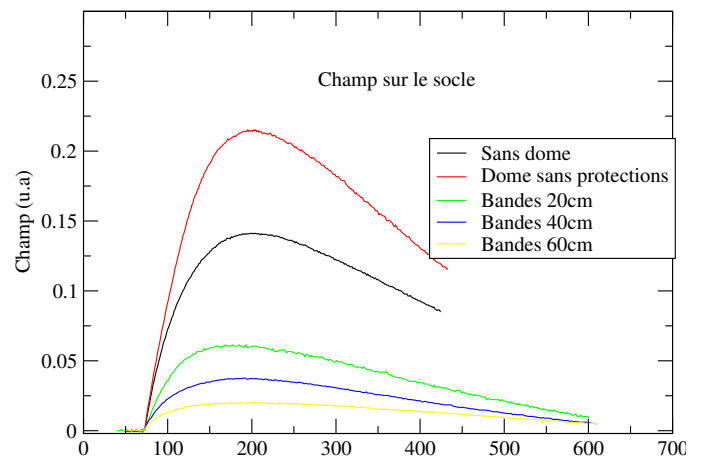
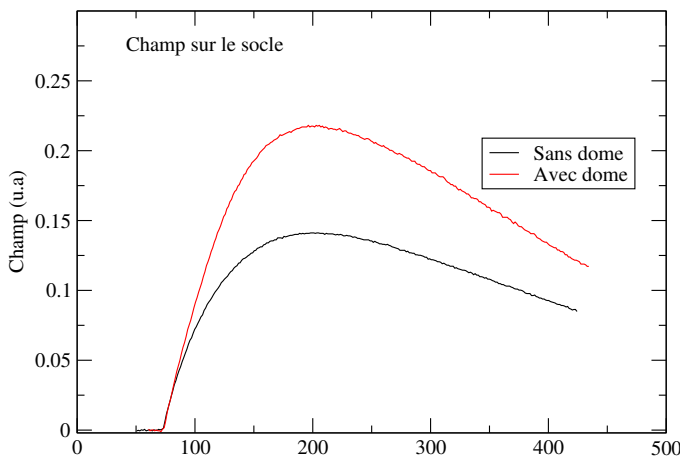
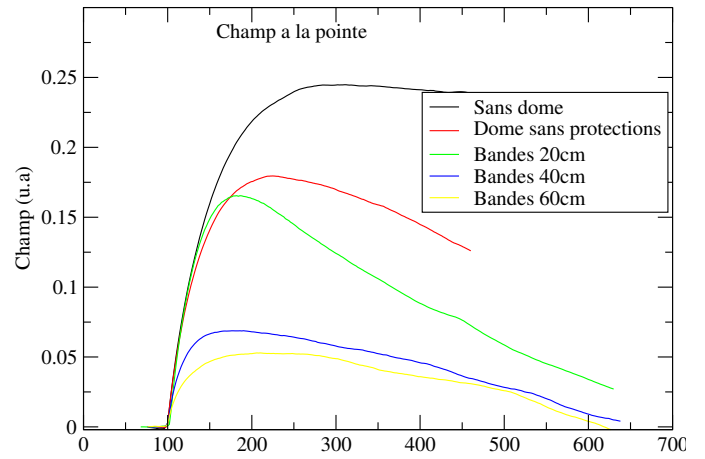
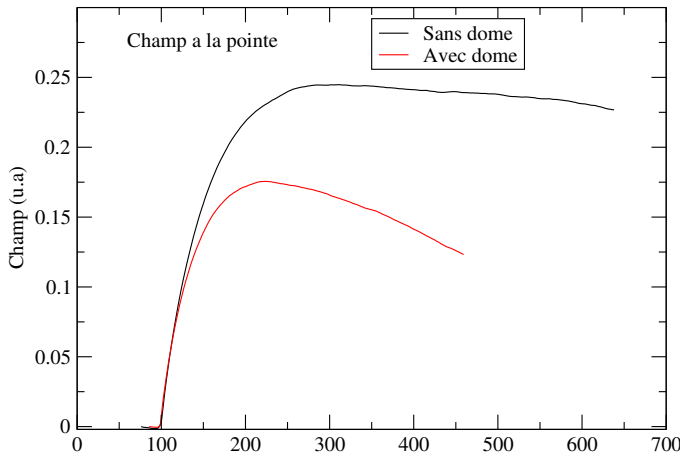


**Figure 16 : Electric field at internal electrode with strips of several types**



**Figure 15 : Electric field at internal electrode with solid strips of several length**

## APPENDIX 2 : WET AIR CALIBRATION



**Figure 17 : Electric field at the internal electrode and at radome base, with and without radome**

**Figure 18 : Electric field at the internal electrode and at radome base, with and without radome, with solid strip of several heights**